

MAGNA DIE[®] and MAGNA DIE[®] 2000 USER'S MANUAL

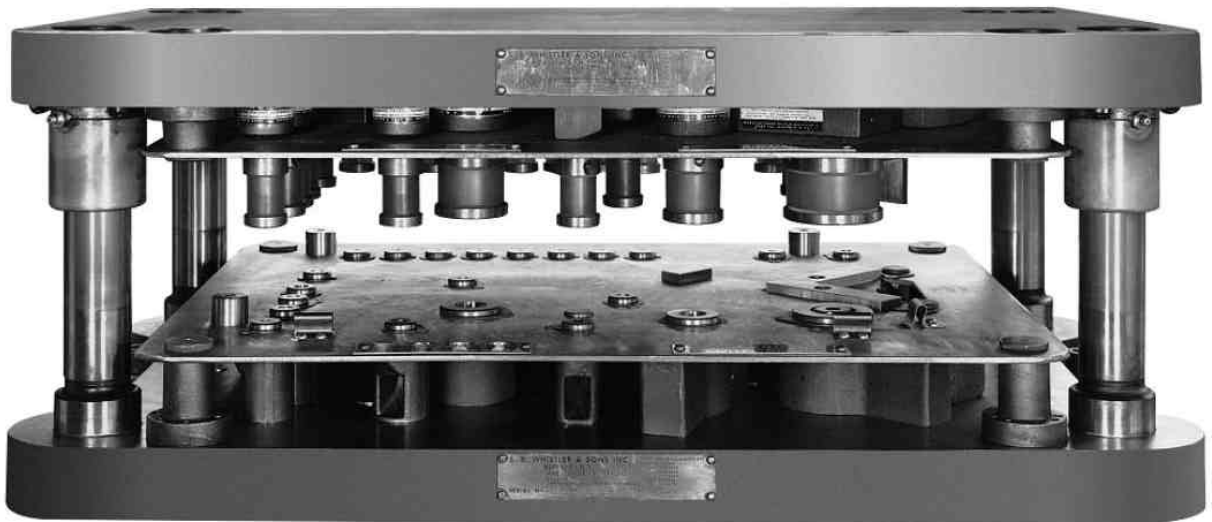

This user's manual is intended to guide users of the Magna Die[®] & Magna Die[®] 2000 Modular Hard Die punching and notching system manufactured by S.B. Whistler & Sons, Inc. of Akron, NY 14001 USA.

For further information, or to place an order, contact our sales department at:

S.B. Whistler and Sons, Inc.

Post Office Box 207

32 Main Street

Akron, N.Y. 14001-0207

Phone: 716-542-4141 • 800-828-1010 • Fax: 716-542-4226

email: sales@sbwhistler.com / engineer@sbwhistler.com

www.sbwhistler.com

CONTENTS

Section "A"- Introduction		PG. 1-2
Section "B"- Receiving the order		PG. 3-6
	-Checking sizes -Relating parts to packing slip	
Section "C"- Press Requirements		PG. 7
Section "D"- Template Design		PG. 8-9
	-Basic Principles -Calculating Tonnage -Calculating Die Clearance	
Section "E"- Template Material		PG. 10
Section "F"- Template Manufacturing		PG. 11
	-Basic Principles	
Section "G"- Set -Up		PG.12-13
	-Work and Storage Area -Basic Setup Procedure -Die template Assembly -Punch Template Assembly	
Section "H"- Operation		PG. 14-15
	-Setting the Shut Height -Loading Tools -Running Parts -Changing Tools	
Section "I"- Maintenance		PG. 16
	-Lubrication -Strippers -Sharpening	
Section "J"- Trouble Shooting		PG. 17-18

WARNING

TO PREVENT SERIOUS BODILY INJURY

- NEVER** PLACE ANY PART OF YOUR BODY UNDER THE SLIDE (RAM) OR WITHIN THE DIE AREA UNLESS POWER IS OFF, FLYWHEEL IS STOPPED AND THE SLIDE (RAM) IS BLOCKED UP.
- NEVER** OPERATE, INSTALL DIES, OR MAINTAIN THE PRESS WITHOUT PROPER INSTRUCTION AND WITHOUT FIRST READING AND UNDERSTANDING THE OPERATORS MANUAL AND PRESS MANUAL.

IT IS THE EMPLOYER'S RESPONSIBILITY TO IMPLEMENT THE ABOVE & ALSO TO PROVIDE PROPER DIES, GUARDS, DEVICES OR MEANS THAT MAY BE NECESSARY OR REQUIRED FOR ANY PARTICULAR USE, OPERATION, SET UP OR SERVICE.

This manual has been written to guide personnel through startup, operation and maintenance of Magna Die® & Magna Die 2000® Modular Hard Die Systems. Product designs, dimensions and tolerances are subject to change without notice.

NOTE: IF THE EMPLOYEE DOES NOT READ OR UNDERSTAND ENGLISH, IT IS THE EMPLOYER'S RESPONSIBILITY TO INTERPRET AND EXPLAIN ALL WARNING SIGNS, ALL INFORMATION CONTAINED IN THIS MANUAL, POWER PRESS SAFETY, PROCEDURES AND RELATED ISSUES PERTAINING TO THE PROPER CARE AND USE OF SUCH PRODUCTS.

SECTION "A"- INTRODUCTION

This manual will assist the reader in understanding and properly implementing Magna Die® & Magna Die® 2000 Modular Hard Die Systems.

Magna Die tooling is manufactured and patented by S. B. Whistler & Sons and incorporates many innovations. Magna Die® tooling is a technical evolution of our original T-slot die system, known world-wide as Adjustable Modular Hard Dies.

Magna Die tooling is designed as an efficient, productive system for punching and notching flat sheet metal in conventional stamping presses and press brakes. Maximum system capacity is .500" / 12.7 mm thick mild steel (AISI-1010 or equivalent). Components are interchangeable and reusable. Features you will appreciate are:

- Top quality tool steel components
- close center punching
- high repeat accuracy
- light weight tooling
- simple assembly
- fast tool changes
- complete factory service and support

The system consists of a Master Die Set and two identically matched, 8 gage steel templates - one to position the punch tooling, the other to position the die tooling. Tool units lock into the templates.

The upper (punch) template and the lower (die) template are located in the Master Die Set over template locator posts and fastened with template clamp screws (TSC-50). The template locator posts are assembled into the Master Die Set at the factory and insure that the punch and die templates are kept in precise vertical alignment throughout the press cycle.

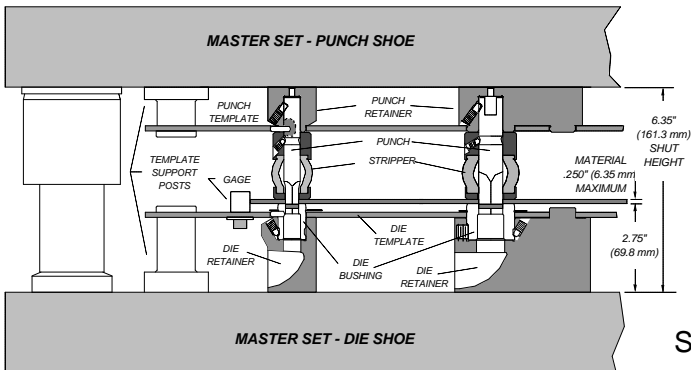

See next page larger image

1. Standard operating shut height is 6.35" (161.3 mm) between working faces of Master Set.

2. It is important to insure that all stripper faces are fully supported by the work piece at bottom of stroke. Lack of support can cause tipping or cocking of the stripper and possible resultant damage and/or injury. Strippers that cannot be fully supported by the work piece (edge notching, for example) must be counterbalanced by attaching a balance pad of the same thickness as the work piece, to the top surface of the bush. Adhesives can be used for this purpose. NOTE THE PRESS MUST NOT BE DRY CYCLED WITHOUT A WORK PIECE WHEN A BALANCE PAD IS BEING USED.

3. Magnetic attraction is achieved through the use of permanent magnet assemblies located in the top of each punch retainer. For optimum magnetic attraction and holding power it is essential that all magnet surfaces be maintained in a clean and smooth condition, free of dirt, slugs and metal particles. Improper maintenance can result in tipping or cocking of the punch retainer, possibly shearing punch and die components and reducing expected tool life.

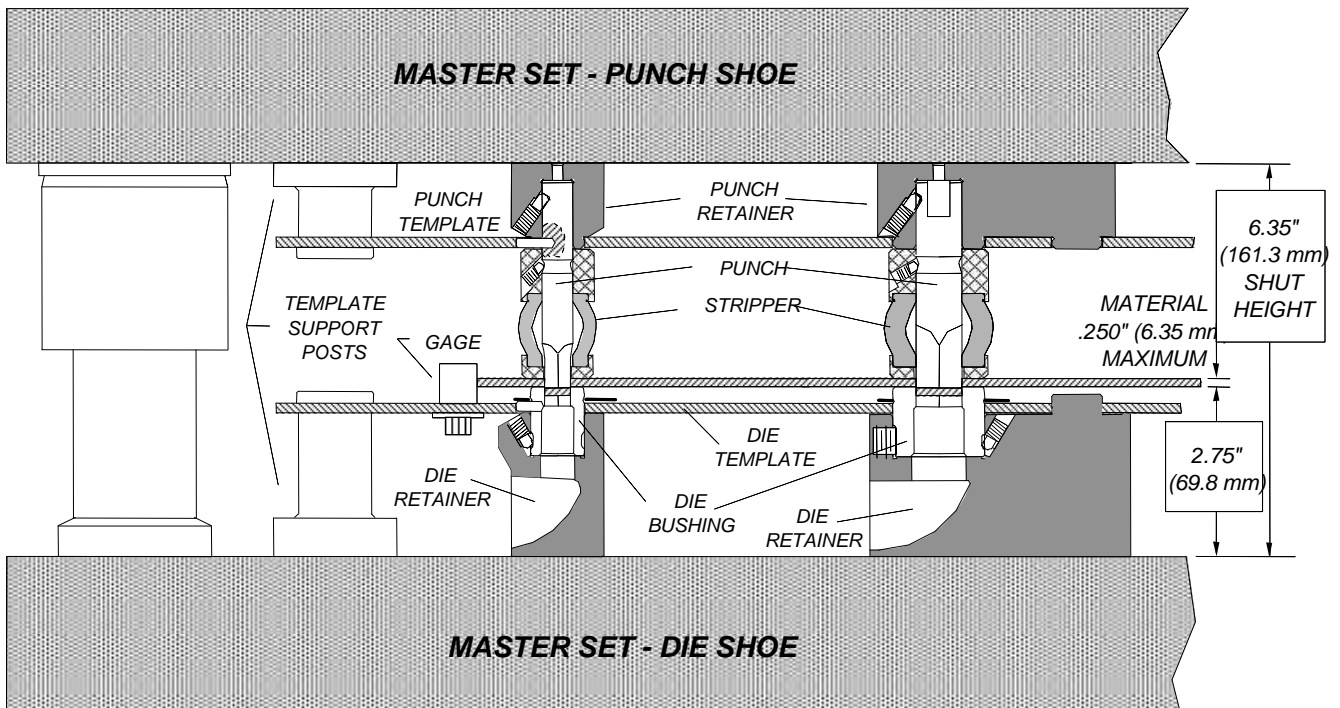

SECTION "B"- RECEIVING THE ORDER

When you receive your shipment, it is important to review the whole order to make sure that all the parts of the Magna Die® system you ordered are accounted for. It is also important to understand how to identify each individual component and how all the pieces fit together. Following are basic illustrations of the Magna Die® components and how they are identified on the packing list. (additional information can be found in the reorder guide).

ORDER NUMBER	ORDER DATE	S. B. WHISTLER & SONS, INC
2480	06/28/01	32 MAIN STREET, PO BOX 207
		AKRON, NEW YORK 14001-0207

PAGE 1

CUSTOMER:

SHIP TO:

REMARKS:*** SHIP UPS NEXT DAY AIR MONDAY DELIVERY ***

P O NUMBER	CUSTOMER	SHIP VIA	REQ. DATE	TERMS
0004802	JLMA	SEE REMARKS	06/29/01	1% 15 NET 30

SALESPERSON	WH
04	1

LN#	QTY	SHIP B/O	ITEM NO. & TYPE	DESCRIPTION	BIN	MFG
1	6		D09471	02 MPU 50 PUNCH ROUND .264		MX
2	6		D05864	02 MDBU 50 BUSH ROUND .272		MX
3	1		D04772	02 MPU 75 PUNCH ROUND .750		MX
4	1		D04878	02 MDBU 75 BUSH ROUND .758		MX

*** P A C K I N G L I S T ***



Magna Die 2000® punch retainers: RMPR / MPR / MPRS50 thru 400 (series)



Punches: MPUL / MPUS / MPU50 thru 400 (series)



Punch Template



Strippers: (2) styles- urethane PMS & PMSX and steel spring; MS & MSX



Clips: MSR50 thru 300 (series)

Bushings: MDBUL / MDBUS / MDBU 50 thru 400 (series)



Die Template



Magna Die® Die Retainers: RMDR / MDR/ MDRS50 thru 400 (series)

For a full listing of each component and reorder details, see the Magna Die® Reorder Guide MRG-00.

Identifying Magna Die® Components and Accessories

In order to maximize the use of your Magna Die®, it is important to learn and understand all the components involved in the system. Below is a brief overview and description of some of the typical items. Your system will have most of these basic components, although some may be unique. The following components are listed in the Magna Die® Reorder Guide MGB-00 in more detail, including dimensions, sizes, etc. It is highly recommended that you review and read the Reorder Guide to better understand the components involved.

Retainer Sets: Retainer sets are available in (8) different sizes/styles determined by the size and shape of the hole being punched. RMU & MU styles are for punching round holes, MUS is used for punching shapes in standard Magna Die® with MPUS style punches. RMU and MU style retainers with added slot are used on Magna Die® 2000 with MPUL style punches.



Punches: Punches range from Series 50 (.500" body diameter) to Series 500 (5.000" body diameter). MPU for round punches, MPUS or MPUL for shaped punches.

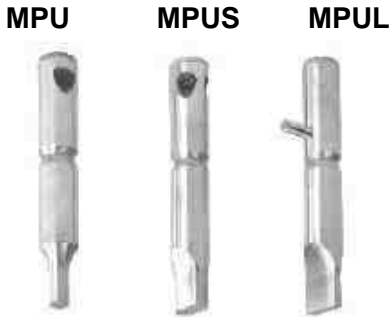

Die Bushings: Bushings are sized to match the punch series with the OD matching the Retainer boss. MDBU for round holes, MDBUS or MDBUL for shaped holes.



Strippers: Light duty strippers for punching up through the 1/8" / 3 mm thick steel are furnished in (2) styles: steel capped polyurethane series PMS and vanadium steel spring series MS. Series PMS is intended for use on medium to high volume punching. Series MS is recommended when only partial support of the stripper is provided while the work piece material and on automated coil applications. Heavy Duty strippers are designed for punching up through 1/4" / 6.35 mm thick mild steel are also furnished in (2) styles: steel capped polyurethane series PMSX (through series 150 only) and vanadium steel spring series MSX. Series MSX is recommended when only partial support of the stripper will be provided by the work piece material.



PMS
PMSX



MS
MSX

Accessories:



TSC-50 : used for securing both punch and die templates to the template support posts on the Master Die Set. Typically (8) are required for each template section (4 on punch template and 4 on die template).



Snap rings : MSR-50 through MSR-500 are used to secure the die assembly into the template.



Gages or End Stops : (2) styles MGA-50-E which has an OD of .750 and MGA-50-D which has an OD of 1.000"



MPG-50 Pilot : used to locate work piece through previously punched holes on hand feed operations. They provide accurate placement for subsequent operations.

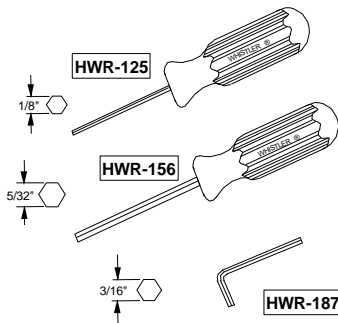

Hex Wrenches : HWR-125 for stripper set screws and HWR-156 for retainer set screws. HWR-187 is used on the template clamp screws TSC-50.

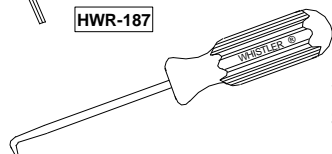

SHR-50 : snap ring hook is for securing/removing MSR snap rings from bushings on the die template.

SECTION "C"- PRESS REQUIREMENTS

The Whistler Magna Die[®] Modular Hard System is intended for use in conventional machine tool stamping and forming presses, either mechanically or hydraulically driven. Typical press styles used are: OBS, OBI, Gap Frame, Straight Side and Press Brake. Other types of machines, such as air powered and the so called "platen press" may be applicable, but should be carefully reviewed with the manufacturer for specific applications.

Magna Die[®] requires a press of sufficient punching tonnage, equipped with working surfaces or filler plates, on both the slide (ram) and the bed which are flat, parallel and free of any openings or depressions which can influence the tooling. Working surfaces should be tough enough to withstand the repeated impact of the punching forces generated by the tool holders. We recommend filler plates made from AISI-1045 carbon steel plate or a similar high strength low alloy.

Operating shut height is 6.35" (160mm) between working surfaces of the Master Set a press with at least 3" (76mm) stroke, or greater, is recommended for hand feeding operations.

Filler plates should be at least equal in size to the overall footprint of the Master Die Set. If filler plates extend beyond or overhang the bed or bolster or slide face, the amount of overhang should not exceed the thickness of the filler plate.

If the unsupported area of the filler plate is greater than the plate thickness, then supporting brackets, adapters, or other means of support should be added to prevent any possible deflection of the filler plate during maximum expected punching load. Whistler will quote, design and manufacture filler plates for your specific application, upon request.

If you are in doubt about calculating tonnage or balancing tonnage load, just ask a Whistler representative about your specific application and we will be happy to assist; or, see page 9 for instructions on how to calculate tonnage. You can also visit the technical area of our website at www.sbwhistler.com to download a useful tonnage calculator.

When calculating press tonnage requirements, remember that press brake capacities should be considered from 1/2 to 2/3 of rated bending tonnage, when used for punching. For example, a 100 ton hydraulic press brake should not be used for a punching application that exceeds 50-67 tons of force. The break through shock of punching can damage hydraulic circuits. Be sure to consult with the press manufacturer. Stop blocks or kiss blocks should also be considered when Magna Die is run in a hydraulic or pneumatic press.

Maximum production efficiency is often a result of operator comfort. If a setup is deep front-to-back and the press bed (tool position) is low, the operator may have to bend or stoop to see the work piece gauges when loading a part. This will become tiresome, resulting in a drop in productivity.

Consider ergonomics, proper lighting and work placement when operating your press. Also, you can consider front gauging, template viewing cutouts and other remedies to the above problems.

SECTION "D"- TEMPLATE DESIGN

Following are design guidelines for Magna Die® and Magna Die® 2000 template sets. There are many ways and opinions on how to design templates. Depending on customer requirements, tooling cost considerations, job complexity and delivery demands, templates can be designed to produce parts in (1) setup, (1) hit, or in multiple setups, with multiple hits. Templates can also be designed for production from strip stock or even from coil-fed material.

Magna Die® template design involves the following (5) steps:

- Step 1 Determine the number of hits and setups to complete a part.
- Step 2 Determine locations of tool components to produce the part.
- Step 3 Determine the quantity and location of gages, pushers, pilots, support buttons
- Step 5 Verify press support area and material flow for template size.
- Step 6 Produce coordinate data and other information needed for template manufacture.

If you have questions about designing Magna Die® templates, please consult our Engineering Department. They will be happy to review the project with you and help determine the best way to punch and notch your product.

The back cover on our Magna Die® Reorder Guide has 1/2 scale retainer layout templates to help you in your template design. Whistler also offers retainer templates in DXF format, downloadable from the technical area of our website at www.sbwhistler.com, to use for designing your own templates.

CALCULATING DIE CLEARANCE: Die clearance is related to the thickness and type of material being punched. For mild steel (AISI 1010/1020) we recommend a total of 10% of material thickness (5% each side) added to the punch size. Clearance should be doubled for stainless steels. Use a total of 8% for light gage softer materials, like aluminum or copper.

Example: To punch a .500" (12.7mm) diameter hole in 11 gage (.120") mild steel, the die size will be .512" (13mm). ($10\% \times .120 = .012 + .500 = .512$).

To determine the size of the guide, add .03 (0.8 mm) to the size of the punch.

CALCULATING TONNAGE:

To calculate punching tonnage use the following shear strength value chart with either the Inch or Metric formulas. To ensure safe operation, it is recommended that any questionable tonnage conditions be reviewed thoroughly with your press manufacturer.

Shear Strength Values

MATERIAL	TONS PER SQ INCH	METRIC TONS PER SQ CM
Aluminum 1100-0 3003-0,6061-0	5.0	0.71
Aluminum 2024-0 3004-H36, 5052-H32	10.0	1.41
Brass & Aluminum 2025-T6, 6152-T6	17.5	2.46
Mild Steel & Bronze	27.5	3.87
Stainless Steel	55.0	7.74

Formula - Inches

Linear inches X Material thickness in inches X Tons per square inch = Tonnage Required

Formula - Metric

Linear centimeters X Material thickness in centimeters X Metric tons per square centimeters = Metric Tonnage Required

NOTE: Add an additional 10% for stripping pressure (multiply by 1.1).

EXAMPLE: How many tons are required to punch fifteen 0.375" (9.52 mm) diameter hole in 16 gage 0.06" (1.52 mm) mild steel ?

Inch

Using the formula of Circumference = 3.1416 X Diameter, determine the linear inches of one 0.375" diameter hole (0.375 X 3.1416 = 1.178"). Multiply by 15 to calculate total linear inches (15 X 1.178 = 17.672"). Select the proper Shear Strength value from the above chart (Mild Steel = 27.5 tons per square inch) and calculate the total tonnage using the below formula.

$$17.672" \times 0.06" \times 27.5 = 29.2 \text{ Total Tons}$$

Add 10% for Stripping pressure

$$29.2 \times 1.1 = 32.1 \text{ Tons}$$

Metric

Using the formula of Circumference = 3.1416 X Diameter, determine the linear centimeters of one 9.52 mm diameter hole (9.52 X 3.1416 = 29.91 mm, or 2.99 cm). Multiply by 15 to calculate total linear centimeters

(15 X 2.99 = 44.85 cm). Select the proper Shear Strength value from the above chart (Mild Steel = 3.87

metric tons per square centimeters) and calculate the total tonnage using the below formula.

$$44.85 \text{ cm} \times .152 \text{ cm} \times 3.87 = 26.38 \text{ Metric Tons}$$

Add 10% for Stripping pressure

$$26.38 \times 1.1 = 29.0 \text{ Metric Tons}$$

SECTION "E"- TEMPLATE MATERIAL

Magna Die® templates are manufactured in pairs (2 pieces). One template becomes the punch (upper) template and the other becomes the die (lower) template. The only difference is in the way that they will be stamped with setup information.

The primary function of the templates is to provide the X - Y (i.e. coordinate) location of the various tool components in the setup. The punch template must also support the weight of the punch tooling between the Locator Posts mounted in the Master Die Set; therefore, it must be adequately rigid. Accessory items such as Hex posts and AMTS-50 Auxiliary Template Supports can aid in this situation. See page 15 in the Magna Die® Reorder guide (MRG-00).

Template holes are machined to precision diameters and accurate locations. Since vertical alignment of the two templates is critical during operation, template material must remain dimensionally stable within the expected ranges of ambient shop temperature.

It would be simple enough to dismiss anything but steel for Magna Die® templates. However, other materials such as aluminum, masonite, hardboard and plastics are occasionally used. For general sheet metal stamping, Whistler recommends the use of low carbon AISI-1008 steel templates.

Plastics can save on the weight factor, but they can be very expensive, less precise, unavailable in the required thickness, may crack and are more difficult to mark with the required information.

Whatever material you choose, its coefficient of thermal expansion and rigidity (modulus of elasticity) must be considered relative to the positioning and weight bearing functions described above.

The template thickness specification for Magna Die® templates is .154"/.162" (3.91/4.11mm). The standard Whistler template stock is AISI 1008, 8 gage hot rolled, pickled and oiled (HRP&O) steel. Mill sheets are put through a rolling process to produce very flat sheets. After the leveling process, the sheets are then sheared to final size.

The steel mill hot rolling process sets up stresses in the steel's micro structure. Steel material used for Magna Die® templates which has not gone through the leveling process may "kink", "oil can" or warp out of flatness, when numerous holes are subsequently machined into it. Leveling the steel to the elastic limit relieves stress, insuring that the finished templates remain dead flat and dimensionally true.

Templates that are not flat can cause misalignment of punches and dies, which will shorten tool life. In addition, a warped template may elevate die retainers, allowing slugs underneath. This may cause damage not only to the Magna Die® system, but may cause damage to the press itself.

SECTION "F"- TEMPLATE MANUFACTURING

There is no one best method for machining templates. Templates are a major component of the Magna Die® system and it is critical that the templates be correct. We recommend that Whistler make the first set of templates for you. This is important because it gives you, the user, a chance to see what the templates should look like, how Whistler identifies and finishes each specific hole, and permits Whistler to warrantee the final product.

If you would like to make your own templates, Whistler will be more than happy to work with you. Just give Whistler a call and we will assist you in any way possible. From advice on how to machine the templates, doing actual layouts or utilizing the DXF disk to aid in design and manufacturing, we can help.

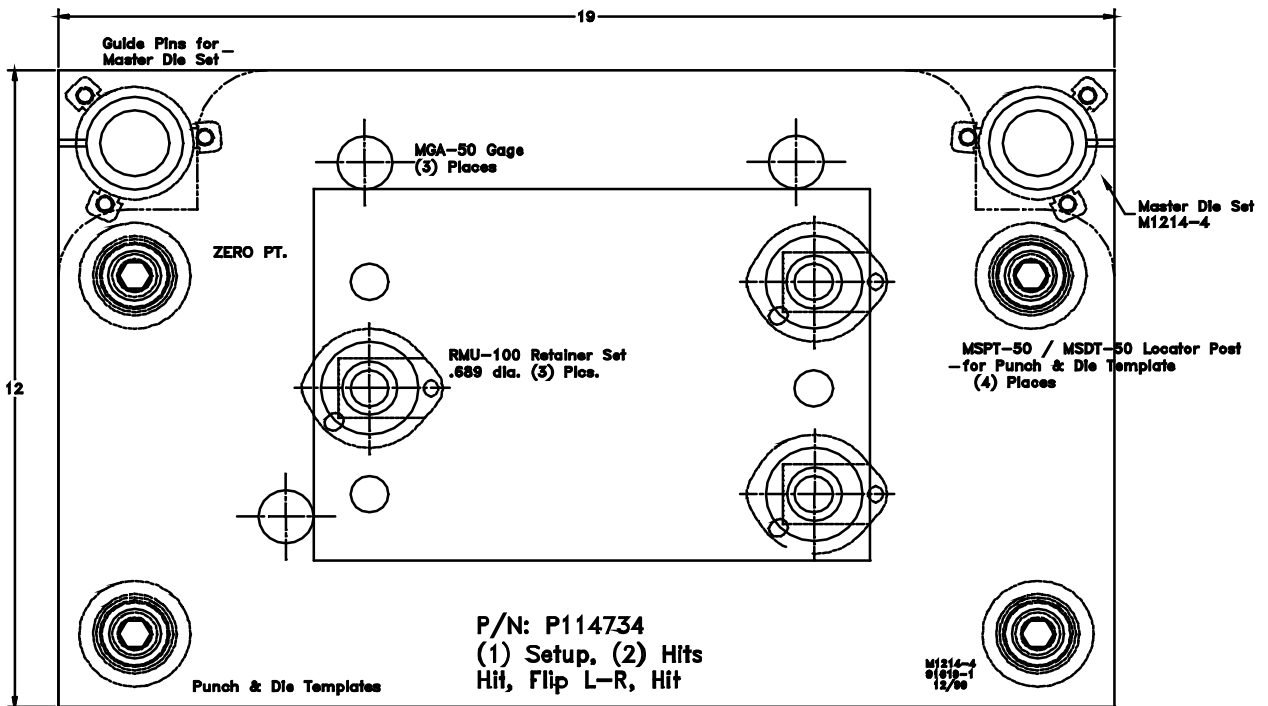

- CAUTIONS:
- 1) Verify slug chute orientation for adequate scrap discharge area.
 - 2) Check job tonnage versus press capacity
 - 3) Design layout for balanced tonnage load
 - 4) Contact Whistler for additional design data on coil or strip-feed applications
 - 5) Multiple station applications should be gauged from the first station edges. Pilots can also be provided if preferred.

SECTION "G"- SET-UP

Work and Storage Area

The tool setup area should be kept clean, well lit and well organized. Tool component bins and drawers should be clearly labeled for efficient location of tools. Steel tool storage cabinetry is the proper way to keep tooling and is readily available from several sources.

Magna Die® templates can be stored in open racks or shelves with vertical slots (angle iron works well) which will support the templates, standing on edge vertically. Store templates as a matched pair in tool number sequence. The photo below provides a general idea for storage planning. When not in use, all tools and templates should be lightly oiled to prevent rust.

Additionally, a horizontal surface for setting templates while loading tools is a must. A table top of wood, plastic or metal will work adequately.

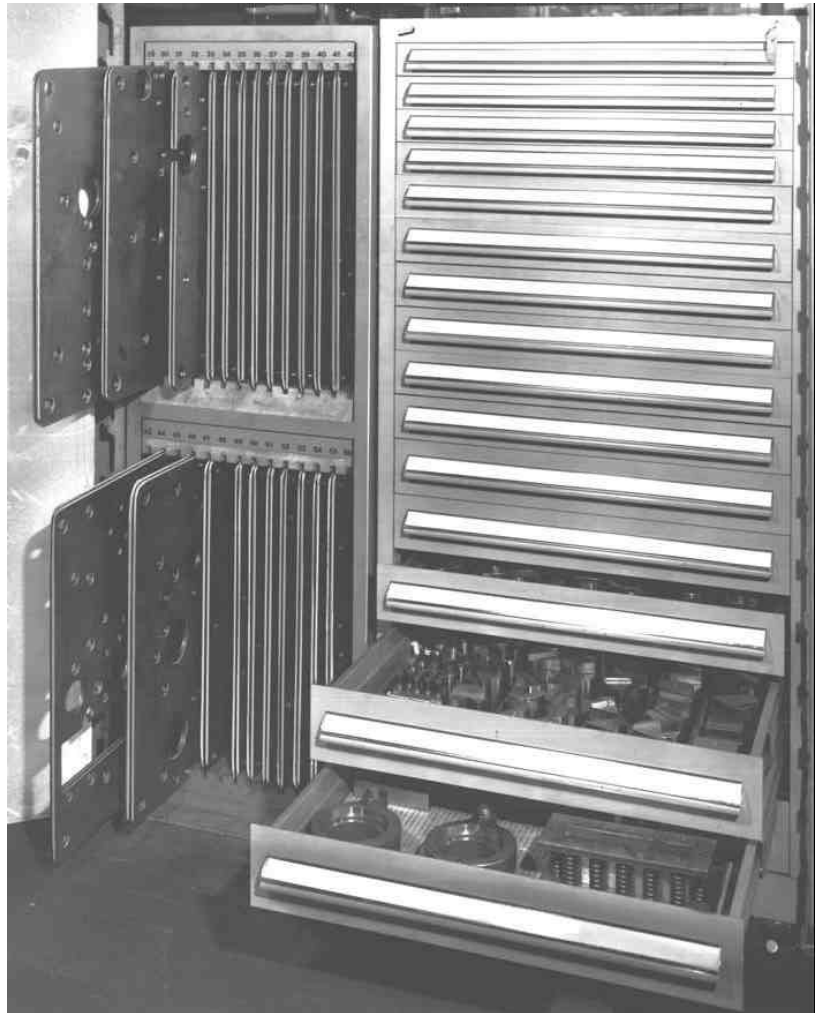
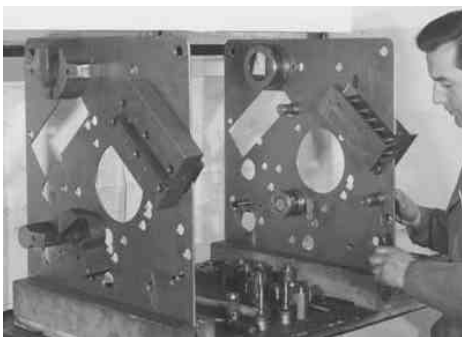

DIE TEMPLATE ASSEMBLY: Start by assembling all die bushings into their respective retainers and tighten the set screws. Then insert die bushing-retainer assemblies into the correct template holes, up through from the underside of the template so that bush cutting edges are on stamped side of the template after insertion. Secure each die bushing with the appropriate 'MSR' snap ring. Start assembling from the center of the template and work outward. Template holes can sometimes be tight, especially in new templates. If so, the use of abrasive emery cloth on the template hole, along with a soft mallet, will facilitate a stubborn fit.

NOTE: *Be certain that all 'MSR' snap rings fully engage bushing grooves. An SRH50 snap ring hook is provided for this purpose.*

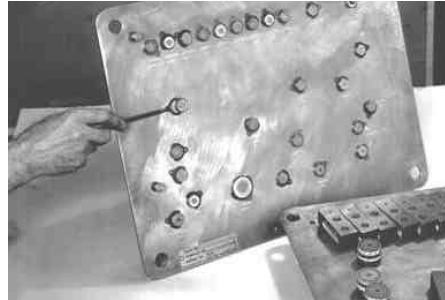

Continue until all template holes for the part to be produced, are loaded with the proper tools. When done, double check all sizes. The size etched on each bushing must match the size code shown on the setup sheet for the subject being assembled.

Check the slug chute direction of each die retainer to insure it will not be facing the operator also to insure that a clear path is provided for punched scrap material. Finally, insert any required gauges (MGA50-E or MGA50-D) and any required stock pushers (MSG50).

PUNCH TEMPLATE: Begin by assembling all the punches into their corresponding punch retainers. Using the same method as loading the die template, locate the punch assembly into the punch template, making sure that the boss of the retainer is all the way through the template bore. After the assembly is in position, slide corresponding stripper over the punch and tighten the stripper set screw to securely lock the punch tool into the template.

VISUAL CHECK: After both punch and die templates are assembled for a specific job, a good visual check will insure that all required tools are inserted and that the direction of any shaped tools are the same top and bottom.

SECTION “H”- OPERATION

SETTING THE SHUT HEIGHT:

Magna Die® and Magna Die® 2000 tooling operate at 6.35” / 161.3 mm shut height between working faces of the Master Die set. At shut height, punch enters .016” / 0.4 mm into die bushing, so it's a good idea to approach shut height carefully the first time, using a piece of paper or cardboard to be punched prior to the working material. Following this recommendation will help prevent damage if some tools are not in the correct location or if the shut height is set too deep.

LOADING THE TOOLS INTO THE MASTER SET:

Occasionally, setups may either be too heavy, or too large to handle manually. In such cases, the use of a fork truck may be necessary to load the templates into the Master Set. If loading templates manually, install the die template first, followed by the punch template. *If using Templacers, then load the punch template first followed by the die template.*

Templacers are used to load/unload punch templates in and out of the Master Set. Templacers – used as a set of 4 – automatically position the punch template onto the locator posts in the punch shoe. To use Templacers, cycle the press to bottom of stroke and adjust ram up approximately .06” / 1.5 mm higher than working shut height. Then cycle press ram to top of stroke. Use the following instructions:

1. Place one Templacer over each of the (4) Die Template locator posts.
2. Set assembled punch template onto Templacers and position (4) aluminum spacers beneath template on die shoe to give support to punch template.
3. Cycle press ram to bottom of stroke and use slide adjustment to make contact with punch retainer magnets.
4. Cycle ram to top of stroke. Magnetic attraction holds assembled template to punch shoe ... insert TCS50 Template Clamp screws.
5. To remove punch template, remove TCS50 Template Clamp screws, adjust ram up approximately 0.06” / 1.5 mm, set Templacers in position, cycle ram to bottom of stroke somewhat past center, break magnetic attraction with pry bars and remove template.

Prior to loading any templates, wipe the Master Set working surfaces clear of all slugs and any other obstructions which might influence tool squareness. Remove any nicks, dents or high spots with a flat file. Also, wipe the bottoms of all the punch and die retainers in case slugs or any other objects are adhering. After you have checked all the tools and made sure that the tools are in the correct position, it is now time to load the templates into the Master Die Set.

If loading manually without using Templacers, then start with the die template first. Simply pick up the die template and slide it into the bottom of the Master Die set. The (4) locating holes in the corners of the template should drop into position over the locating posts in the Master Set. After the template is in place, secure it by installing the TCS-50 template clamp screws into each corner post.

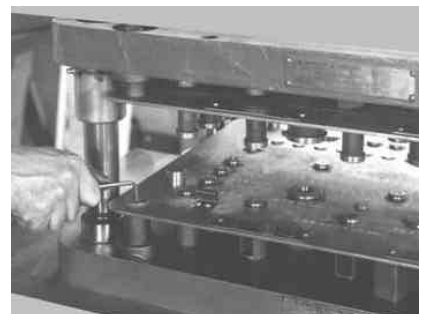

Use the same procedure to load the punch template. Note that as the punch template is lifted toward the punch shoe, magnets on the back of the punch retainers will cause the punch template to “jump” into position. The magnetic attraction will hold the template in position while the TCS-50 template clamp screws are secured into each corner post.

RUNNING PARTS:

Process the work piece material according to the operational procedure that the system was designed for. (i.e. 1 hit, 2 hits, hit, flip, hit, etc.). When running a job, the press operator should be observant of the tool performance and of any the slug accumulation. It may be necessary to clear away slugs, since scrap can sometimes build up over time, depending on hole density and run volume. Make sure that all die retainers are firmly seated on the Master Set shoe so that slugs do not get underneath them. No “daylight” should be visible under die retainers and this should be checked periodically as required.

CHANGING TOOLS:

Changing Magna Die® or Magna Die® 2000 tool setups is a simple and easy process. First, remove the (8) TCS-50 template clamp screws (four on the top and four on the bottom). Next, place a couple wood 2x4 parallel blocks or an appropriate piece of plywood on top of the die template for protection as the punch template is dropped. To remove the punch templates, use the wooden pry bars provided. By exerting uniform downward pressure on the pry bars between the top shoe and the punch template, the magnetic attraction is broken by prying the punch template away from the shoe. Let the punch template assembly drop down onto the 2x4 parallel blocks or plywood, from where it can be removed to the setup / assembly area. Then lift the die template off the corner posts and return it to the setup or assembly area.

With a rag or brush, completely wipe down the entire press bed, removing all slugs and checking for any nicks or dents. Repeat all the instructions that were noted previously in the LOADING TOOLS section of this manual to prepare and install your next setup. It is possible to achieve a tool change (i.e. press down time) in less than two minutes, if the next template set is pre-assembled.

You may need to use some tools from the current setup in order to prepare the next setup and obviously this will slow down die changeovers, defeating one of the major advantages of the Magna Die® system concept. We have found that many Magna Die® users, as they develop their systems over time, will accumulate sufficient tool inventories to minimize this potential for delay. In fact, some users regard Magna Die® benefits and cost to so advantageous that they will approach each setup on a fully tooled basis, never dismantling a setup.

SECTION "I"- MAINTENANCE

LUBRICATION:

Except for the main guide pin bushings, Magna Die® systems generally do not require lubrication of any kind. The main guide pin bushings should be greased prior to any production run, same as they would be with any conventional die set. Depending on the work piece material type and application, conventional stock oilers can be used without problem, if desired.

SHARPENING PUNCHES AND DIES:

New Magna Die® punches and die bushings are provided with approximately .100" / 2.5 mm of life for sharpening, depending of the application. Sharpening should be done with a soft grade 40-60 bonded grit surface grinding wheel to prevent glazing, and with full coolant flood so the tools will not overheat during the grinding process. Punches and die bushings should be held in a 'V' block to maintain parallelism between top and bottom and minimal stock removal should be maintained for each pass.

Whenever possible, punch and die bushing lengths should be uniform – particularly with die bushings – where excessive variations in heights could cause distortion on the surface of the stamping.

With modular tooling it's usually a good idea to standardize on the amount of sharpening, approximately in increments of .012" / 0.3 mm for example. Whistler does not recommend shimming as a general rule, Therefore, after sharpening, shut height should be adjusted downward accordingly. For standard hole punching and notching where cutting edges bypass each other, new punches can generally be used alongside sharpened punches without any problem, since new punches will simply enter further into their respective die bushings.

In the case of forming punches and dies where depth control is important, for example, embossments, lance/forms, extruded holes and electrical knockouts, some shimming may be necessary to return formed shapes to required length specifications, but any shimming should be minimized and controlled very carefully when necessary. Based on your in-house capability to sharpen punches and die bushings where shapes and form depths are critical, it may be more advantageous to return these to Whistler for periodic sharpening and maintenance.

CORNER NOTCH DIES, CUT-OFF DIES:

To sharpen cutting edges on the die steels of corner notch dies, remove the mounting screws and lay the steels flat on a rotary or surface grinder chuck. The same grinding procedures listed above with respect to wheel type and coolant, should be observed. Avoid grinding die steels on the top or bottom surface, so that the original height can be maintained. When reassembling die steels after grinding, it may be necessary to use washers under the bolt heads to insure that steels are tight, since the bore holes are "blind" tapped.

To sharpen the corner notch die punch steel, unscrew the stripper bolts and remove stripper. Each bolt should be marked as removed so that it can be returned to its original hole at reassembly. Clean the magnet surface of the punch shoe and lay on the surface grinder table or chuck. Shim punch shoe .020" / 0.5 mm to maintain proper shear, with the 90 degree corner being the leading point. Then follow the same procedures noted above with respect to wheel, stock removal and coolant.

SECTION "J"- TROUBLE SHOOTING

<i>PROBLEM</i>	<i>CAUSE</i>	<i>SOLUTION</i>
<i>UNEVEN PENETRATION DEPTH</i>	<ul style="list-style-type: none"> - INADEQUATE TONNAGE - RAM NOT PARALLEL TO BED - PUNCHES SHARPENED BUT NOT SHIMMED 	<ul style="list-style-type: none"> -CHECK TONNAGE REQUIREMENT - ADJUST PRESS GIBBS. - CENTER TOOLING LOAD UNDER RAM - ADD SHIM TO PUNCH (ES)
<i>KNOCKOUTS CUT THROUGH</i>	<ul style="list-style-type: none"> - RAM DEPTH SET TO DEEP - RAM OVER TRAVEL 	<ul style="list-style-type: none"> - INCREASE SHUT HEIGHT - ADD PRESS STOP BLOCKS
<i>HOLE PATTERN NOT CONSISTANT WITH EDGE OF SHEET</i>	<ul style="list-style-type: none"> - GAGE POSITION - PART LOADING - IMPROPER GAGE POSITION 	<ul style="list-style-type: none"> - RECHECK BLANK SHEAR SIZE - REVIEW PART DESIGN PRINT AND TEMPLATE LAYOUT - VERIFY GAGE LOCATIONS
<i>STRIP FEED STICKS TO DIE BUSHING</i>	<ul style="list-style-type: none"> - STRIP BURR CATCHES IN DIE 	<ul style="list-style-type: none"> - ADD LIFTERS TO RAISE STRIP WHEN MOVING
<i>WORKPIECE DOES NOT STRIP FROM PUNCH</i>	<ul style="list-style-type: none"> - TONNAGE - FATIGUED STRIPPERS 	<ul style="list-style-type: none"> - RECALCULATE TONNAGE -REPLACE STRIPPER OR SPRINGS
<i>BROKEN PUNCHES</i>	<ul style="list-style-type: none"> - ROCKING OF PUNCH DURING PUNCHING - TEMPLATE BENT SO PUNCHES ARE NOT VERTICAL -SLUGS UNDER DIE RETAINER 	<ul style="list-style-type: none"> - RAM MOVING F-B, OR L-R UNDER LOAD. STOP BLOCKS AND CENTER LOAD UNDER RAM -STRAIGHTEN / REPLACE TEMPLATES - CLEAN PRESS BED SURFACE THOROUGHLY

<i>PROBLEM</i>	<i>CAUSE</i>	<i>SOLUTION</i>
<i>EXCESSIVE BURR ON WORKPIECE</i>	<ul style="list-style-type: none"> -DULL PUNCHES OR DIES -EXCESSIVE DIE CLEARANCE - WORN POST ASSEMBLIES - RAM/BED OF PRESS NOT PARALLEL UNDER LOAD -WORKPIECE MOVING DURING PUNCHING 	<ul style="list-style-type: none"> - <i>REPLACE OR SHARPEN PUNCHES OR DIES</i> -<i>CHECK MATERIAL TYPE & THICKNESS ADJUST CLEARANCE AS NECESSARY.</i> - <i>STOP PRESS AT BOTTOM OF STROKE. MEASURE RAM TO BED DIMENSION AT 4 CORNERS. USE STOP BLOCKS OR REPAIR PRESS.</i> -<i>VERIFY PUSHERS ARE INSTALLED AND FUNCTIONING</i>